



# Refurbish and static reinforcement of tunnels: innovative construction methods and materials

Martino Gatti<sup>a</sup>, Giorgio Giacomini<sup>b</sup>, Gilberto Masnaghetti<sup>a</sup>, Giuseppe Lunardi<sup>a</sup>

<sup>a</sup> Rocksoil S.p.A., Via Corridoni 13, 20122 Milano, Italy

<sup>b</sup> G&P Intech S.r.l., Via Retrone 39, 36077 Altavilla Vicentina, Vicenza - Italy

*Keywords: Refurbish; reinforcement; tunnel; innovative materials.*

## ABSTRACT

The ever-increasing use of underground space for the construction of transport infrastructures increases the tunnel network to be maintained over time, by restoration and repairing works sometimes structural in nature. At the same time the development and research into new materials led, over recent decades, to a widespread use of composite fiber-reinforced or high-performance materials in the world of civil construction, which can be usefully adopted for tunnels repairing. The paper will describes usual repairing procedure and some interesting products, such as two-component thixotropic rheoplastic mortar and very high strength galvanized steel fabric UHTSS to use for structural reinforcements. The design approach, some typical schemes and notes to dimension the reinforcement will be illustrated, together with a case-history applied by the Authors for the rehabilitation of tunnels part of the A1 Bologna-Florence Motorway.

## 1 INTRODUCTION

The maintenance of the existing infrastructures is one of the most important issue for the constructions' market; for the infrastructures, as well as for the buildings, the refurbishment and restoring are priority activities today, in order to maintain the value of the existing works and guarantee safety conditions for users. Tunnels are among the most difficult to operate, considering they are in direct contact with soil and groundwater and the exposure classes could be very severe. Moreover they can be affected by soil movements and land settlements or seismic events (for the shallow tunnels), so that additional load conditions can arise during their life time, stressing the support linings. This is especially true for the infrastructures built in Italy in the 60<sup>th</sup> and 70<sup>th</sup>, during the post-war economic boom, when a rapid expansion of the transport network took place, sometimes with technologies still to be perfected.

Thus, in the next few years, a lot of interventions should be applied, so that monitoring and control systems on one side and specialist reinforcement techniques on the other should be calibrated in anticipation of a very intensive use.

The paper presents a methodology approach, to be applied to define the state of preservation of the underground structures, to evaluate the level of damages and to choose the proper solutions for the restoring. All considering that the diagnostic and maintenance activities should be done, in many case, in tunnels under service, looking for reducing as much as possible the impact on the normal operation. Some case histories will be illustrated too.

## 2 METHODOLOGY APPROACH

The new design approach, according to recent Codes and Regulations, provides for the preparation of a "maintenance plan" for any project in the design stage, in which to identify the type and frequency of the checks that must be conducted to guarantee the functionality and durability of the structures. This approach was not usual in the past and for many years a punctual verification of the state of the structures was not provided. So to evaluate the conditions of existing structures, detailed inspections and survey must be executed first, to find out the

problems that must be deepened and solved. These following steps could be followed:

- the execution of a “general survey” of the investigated structure for the definition of the state of decay and to highlight local problems, if any;
- the execution of in situ and laboratory tests to define the mechanical and geometric properties of the structure and the existing stress state;
- the preparation of an interpretative model of the phenomena detected, able to evaluate the causes and to dimension the repair intervention
- the definition of the most appropriate technologies and work phases (construction methods and materials).

### 3 GENERAL SURVEY

The general survey must include a detailed mapping of the structures’ conditions. With reference to tunnels, the internal surface (sidewalls and crown) and the sidewalks and pits should be mapped and reported in detail in graphical schemes. In case of concrete structures, the survey should include: a) the presence of deteriorated surface, b) the spalling situations (especially for the concrete cover in case of reinforced concrete), c) cracks phenomena, measuring the geometry, depth and width, d) areas of humidity and water presence, which has great importance on the concrete durability. Consider that until the 80s the tunnels were not waterproofed, so that is not unusual to find local water inflow which caused very local damages. In case of masonry structures, typical of old railway tunnels, the survey have also to consider grout and cement mortar conditions and broken bricks.

The survey will mainly have to distinguish the superficial deteriorations from the most critical situations that can be related to static suffering, mainly linked to cracking evidences, to be investigated in more depth by tests.

### 4 INVESTIGATION METHODS AND TESTS

In case of local critical situations, in order to better understand the real conditions and the causes, in situ and laboratory tests are generally performed as described in the following, coupled with a monitoring program in order to evaluate the evolution of the phenomena.

#### 4.1 Laserscanner and georadar investigations

Sometimes it can be very useful to evaluate the thickness of the linings, in order to verify if there have been casting problems during construction that have generated reduced thicknesses. Reduced thicknesses are in fact one of the main causes that lead to cracks in the linings. This check can be easily performed by means of georadar investigations (GPR Ground Probing Radar). This technique is also able to evaluate the compactness of the concrete, highlighting the possible presence of voids, damaged areas or any parts of the lining that are becoming detached. The georadar is able to highlight any discontinuity within the thickness of concrete and to clearly identify the interface with the material behind it, be it ground or pre-lining. The survey by georadar provides the introduction of a short electromagnetic pulse in the lining by means of an antenna, whose frequency can vary from 400 to 2,600 MHz (mainly 750 Mhz is used). The impulse propagates in the material with a speed that depends mainly on the dielectric constant of the material same. When the impulse meets an interface with dielectric properties different from the medium, it’s partially reflected on the surface. Figure 1 show a typical feedback from investigation, from which the thickness of the lining, and defects if any, could be defined.

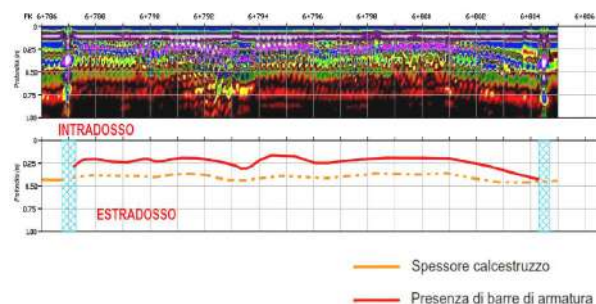

Figure 1. Georadar investigation

Laser scanner can instead be very useful for verifying the tunnel's clearance, highlighting the possible presence of deformations of the intrados; furthermore it allows to carry out an accurate survey of sectors where there are detachments or spalling of concrete.

#### 4.2 Stress investigation: doorstopper tests and flat-jacks

In order to evaluate if cracking or damages of the linings are related to static problems or not, it is essential to assess the stress state within the linings: in situ tests must be carried out, by performing flat jacks or doorstopper tests.

The “doorstopper” test provides for the measurement of deformations that occur in the central area of the bottom of a probe hole (diameter equal to 76 mm), following the release of the stresses obtained by over-cutting. This measurement is carried out by means of a cell, that incorporates 4 electrical resistance strain-gauges placed at 45° to each other, which is glued to the bottom of the hole. Once the zero measurement of the strain-gauges has been carried out, the stresses in the concrete are released by deepening the hole with a simple core barrel (internal D=61 mm), recovering the core together with the measuring cell glued to it. It is so possible to measure the deformations caused by the release of the stresses in the cell and – once defined the elastic modulus of the sample – define the stress into the concrete. A schematic representation of the various test phases is shown in the following figure 2.

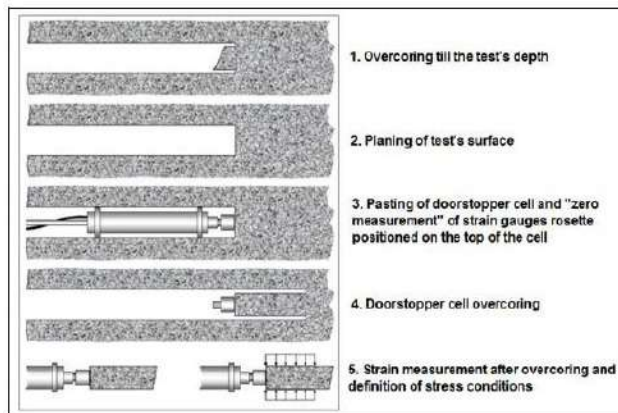

Figure 2. Doorstopper test

The tests are performed both in intrados and extrados of the lining, so to have the stress state across the whole transverse section of the lining. Generally, 3-4 couple of tests are performed, in correspondence with the crown and the sidewalls, to determine the stresses (and consequently bending moment and axial loads) along the development of the linings, as showed in Fig.3.

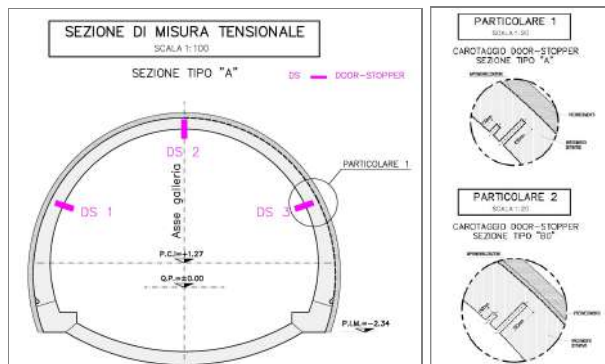

Figure 3. Doorstopper tests' location

Alternatively, flat-jack tests can be used, which are simpler to perform, even if they allow the evaluation of the stresses only in the intrados and in the case of compression stress.

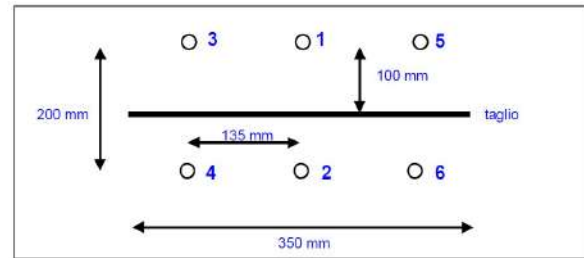

Figure 4. Flat-jack scheme

With reference to Figure 2, the test provides the installation of six target located across the future cut; a zero reading is done, followed by the cut's execution and by the positioning of the flat-jack inside the cut. The pressure is raised in the jack until the position of the bases is restored in the zero reading; this recovery pressure, with some corrective factors related to the geometry of the instrument, represents the stress in the lining.

To evaluate the safety conditions of existing structures it's also necessary to assess the strength of the structural materials: UCS tests must be performed for concrete samples.

#### 4.3 Cracks monitoring

It is very important to understand if cracking phenomena are still evolving or they are now stabilized. For this purpose it is necessary to set up a monitoring survey using cracks-readings able to accurately detect any movements.

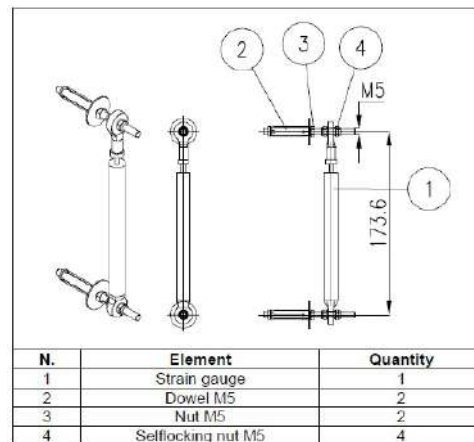

Figure 5. Electrical crack-meters

It is preferable to use electrical crackmeters, equipped with automatic datalogger (UAD) and temperature meter: this allows the automatic reading of the monitored crack opening, evaluating the resistance variation of a circuit placed on the strain-gauge bar. They consist of two measurement bases installed on either side of



the crack to be monitored with dowels, and a central body equipped with an electrical transducer as shown in the following Figure 5.

Some mechanical crackmeters are placed too, where the measurement is performed manually using precision analogue instrumentation (millesimal comparator - sensitivity 0.001mm), for comparison with the automatic readings. It very important to record the temperature variations too, so to evaluate if crack movement can be related to them.

## 5 PROBLEM MODELLING

The data collected allow us to express assessments about the causes of the damage found. In many cases there are no critical stress situations and the monitoring carried out shows a stabilization of the cracking phenomena. In these cases the deteriorations are therefore attributable to the old age of the structures and to the prolonged time under service, or to defects of construction, such as irregular joints, cracks for shrinkage or temperature effect during the casting: it is possible to proceed with cosmetic restorations, rehabilitation of cracks without paying attention to aspects static in nature. If instead the collected information indicates the presence of static problems, of interaction between ground and structure or the damage is such as to create risks for the structures' stability, it is necessary to prepare an "interpretative model" of the situation to have data to design in detail the strengthened intervention. It is necessary to search about construction data, such as the construction phases, the support section adopted for the excavation, the typologies of the pre-linings and linings and, finally, the monitoring data recorded during construction and in the service period.

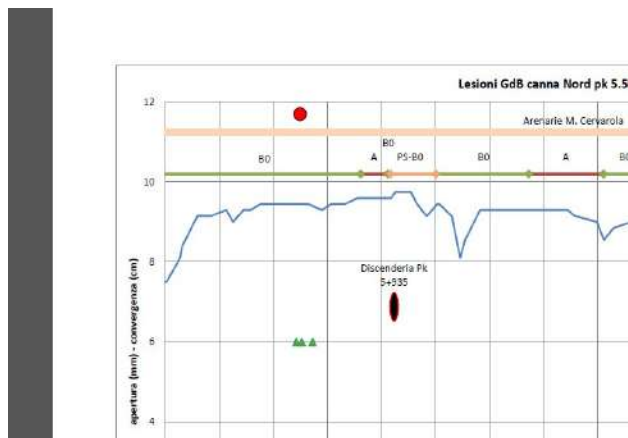

Figure 6. Summary of construction data

Figure 6 reports a typical diagram with the summary of the construction data along the tunnel alignment: geological condition, presence of faults, weak-zones, geo-mechanical rock-mass parameters (GSI, RMR ...) and deformation during excavation (pre-linings convergence and settlements and final linings movements).

These information, together with the data collected by the investigations presented in the chapter 4, are used to prepare "numerical models" which represents, by means of a back-analyses approach, the up today situation (Fig.7).

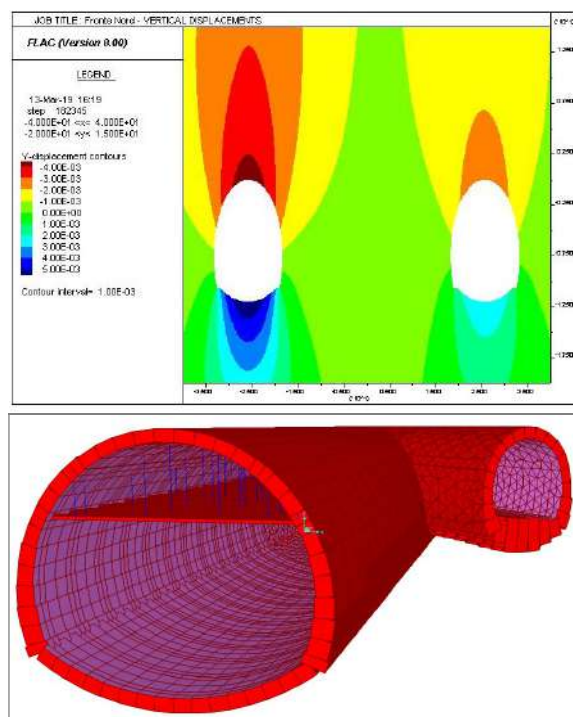

Figure 7. Examples of 2D-3D FEM numerical models

With this model it is possible to reproduce the suffering area of the lining and to evaluate the forces acting - bending moment, axial force and shear - to use to dimension the reinforcement.

A particular consideration concerns the seismic actions: the most recent regulations require assessing the safety of infrastructures during seismic events. This requirement also applies to tunnels, especially those with low coverage. Many existing galleries were not dimensioned to cope with similar events. Here it is sometimes necessary to evaluate its behaviour under earthquake and evaluate the necessary reinforcement interventions. It's so necessary to perform the investigations described at chapters 3 and 4 and to prepare a model involving all the available information. Once the seismic actions have been evaluated according to the expected accelerations, the service life of the structures and the consequent return period of the seismic event, they will be applied to the model so as to assess

whether they are compatible, or not, with the resistance characteristics of the structures and consequently define the necessary strengthened interventions. Simplified methods, according to Penzien (1998 and 2000) or Wang (1993) can be usefully applied.

## 6 CONSTRUCTION METHODS AND MATERIALS

According to the typologies and causes of the damages, several interventions can be applied, from simple sealing of the cracks to placing steel plates and reinforcement materials. Some of the more usual interventions are presented below.

### 6.1 Cracks repairing (opening 1.0-1.5 mm)

If cracks' opening is less than 1.0-1.5 mm and the location is transversal to the axis of the tunnels (this means transversal joints, cracks dividing lining in blocks), you can proceed with the sealing of the cracks following these steps:

- a) making a cut, with a grinder, for a depth of 100-150 mm (thickness of about 2-3 mm) along the entire crack;
- b) washing of the cut with pressurized water;
- c) preparation and application of ready-to-use cementitious mortars with two-component thixotropic properties. The mortar is applied directly by trowel, exerting good pressure and compacting.

### 6.2 Cracks repairing (opening >1.5 mm)

If cracks' opening is greater than 1.5 mm, you must seal the cracks by injections, by:

- a) execution of holes with Ø8 mm bits along the entire axis of the crack with a 45° inclination, alternating on the right and on the left of the crack, so that they intercept the surface of the crack itself;
- b) cleaning of the holes with compressed air and insertion in the holes of special PVC or copper tubes;
- c) sealing the applied tubes and the external surface of the crack with a two-component epoxy adhesive for structural bonding.
- d) after approximately 24 hours, once the adhesive has hardened, each tube will be cleaned again by compressed air, checking at the same time that the tubes and the external seal are well sealed.
- e) two-component epoxy resin, with very low viscosity, will then be injected; the application of the material will take place

with a pneumatic or manual injection pump, pumping the product inside the prepared tubes. The injection will start from the lowest tube and will continue until the product comes out of the tube immediately above.

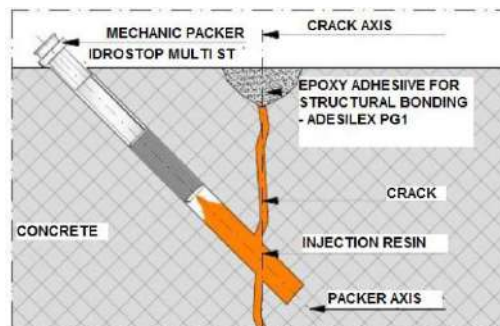

Figure 8. Cracks' sealing procedure

- f) Once the injection operation is completed, the tubes will be cut to the level of the concrete and the surface sealing will be checked and eventually completed with a two-component epoxy adhesive for structural bonding.

### 6.3 Sealing materials

For the intervention described at chapter 6.1, a cementitious mortar, such as MapeGrout LM2K, is generally used: class R3, UCS equal to 10 MPa after 24 hours and greater than 35 MPa after 28 days, elastic modulus > 15 GPa, adhesion greater than 2.0 MPa (according to EN1766) and fire resistance class E. For intervention described at chapter 6.2, an epoxy adhesive, such as Adesilex PG1, is used to seal the tubes and the external holes: a 3.0 MPa adhesive, according to EN12636 is required, UCS greater than 50 MPa and workability in the range 30-60 minutes with hardening in 5-7 hours. Finally, for cracks' injection, two-component epoxy resin, such as Epojet or Epojet LV, is used: with very low viscosity ~ 140 mPa·s and shrinkage control < 3% (according to EN 12617-2); UCS > 60 MPa.

### 6.4 Strengthened interventions

When the cracking phenomenon is very extensive and static problems are presumed, it may be necessary to carry out reinforcement interventions, increasing the resistance characteristics of the linings. It is the case where plain concrete linings are not able to support tensile stresses, connected to not symmetric loads, seismic actions, local ground pressure; it is therefore necessary to correct the resistant section applying new materials with high performance: carbon plates and composite materials (FRP),

fiberglass materials (GFRP) or high strength galvanized steel fabric (UHTTS) represent the proper solutions (Armellini, 2015, Bacchettini, 2014). For tunnelling applications, the use of high strength steel, such as Steel Net fabric, is a very flexible solution, able to increase the tensile strength capacity of the linings with a reduced variation of the thickness, so to preserve the clearance of the section. The Steel Net is embedded into a mortar layer, after removing few centimetres of the existing concrete. These are the execution phases:

- removal of a concrete thickness of about 45-50mm (not greater than the cover for reinforced concrete);
- cleaning the surfaces to reinforce, removing any damaged or incoherent parts;
- roughening of the concrete surface and restoration of any missing volumes with adequate mortars;
- installation of a first layer of bicomponent mortar R4, such as Concrete Rock V2, using a trowel, for a layer of 15-20 mm;
- positioning of the layer of fabric in UHTSS galvanized steel such as Steel Net 220, into the fresh mortar, transversal and/or longitudinal, taking care to perfectly impregnate the fabric avoiding the formation of wrinkles or bubbles;
- installation of the steel connectors, such as SFIX G 10-12, drilling the concrete lining and injecting special mortars/resins for grouting the connecting elements;
- installation of the final layer of bicomponent mortar R4, such as Concrete Rock V2, reaching a protective thickness against a possible fire, equal to about 30-35 mm (total mortar thickness 50-60 mm).

In this way, part of the existing lining is replaced with high performance material, able to support tensile stresses and to increase bending capacity.

Figure 9 represents a typical intervention: in order to cover cracking area, a longitudinal and some transversal (each 1.00 m) Steel Net fabrics are placed, sewing the crack. 50 mm of concrete cover are removed and replaced with bicomponent mortar (first layer 15 mm and final layer 35 mm).

The UHTTS steel net fabric is prepared as a tape, width 300 mm, equivalent thickness 0.27 mm (2.72 mm/cm<sup>2</sup>), tensile ULS 6900 KN/cm, elastic modulus > 190 GPa and tensile strain > 1.6%. For the connections, galvanise steel elements are suggested, 10-12 mm in diameter, with tensile strength greater than 2400 MPa and tensile strain > 1.6%. Finally the requirements for

the bi-component mortar: UCS > 45 MPa and adhesion > 2.5 MPa is generally required.

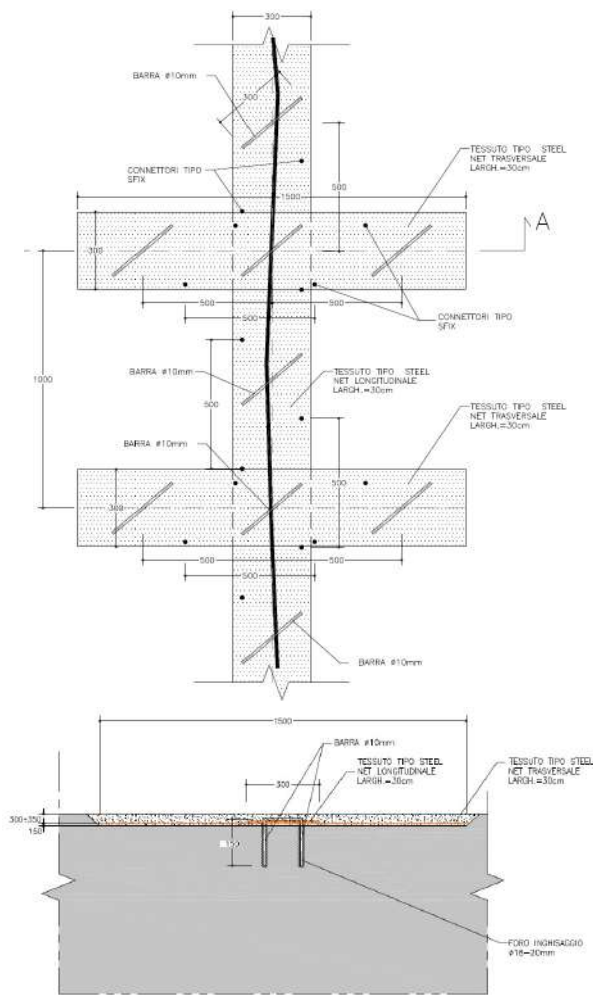

Figure 9. UHTTS steel net fabric intervention

### 6.5 The use of steel plates and steel linings

A stronger reinforcement is the placing, in the intrados of the linings, of steel plates, with thickness ranging in 15-30 mm according to static needs, connected to the existing lining by steel bolts. This intervention is able to increase both the bending capacity of the lining, supporting tensile stresses, and the shear capacity increasing its stiffness. A coupled section steel-concrete should be considered: the plain strain state is guaranteed by the connectors; generally steel bolts, M24-M30, with drilling hole 30-38 mm and depth 250-300 mm, are used.

In this application too, few centimetres of the existing concrete will be removed so to maintain the final thickness of the existing lining; in order to arrange the steel plates with the geometry of the linings – which can present defects or irregularities – the plates are positioned 30-50 mm far from the intrados of the lining: this space will be filled by mortar R3-R4.



The steel should be covered by intumescent paints to be protected from fire. Figure 10 shows the detailing of the intervention

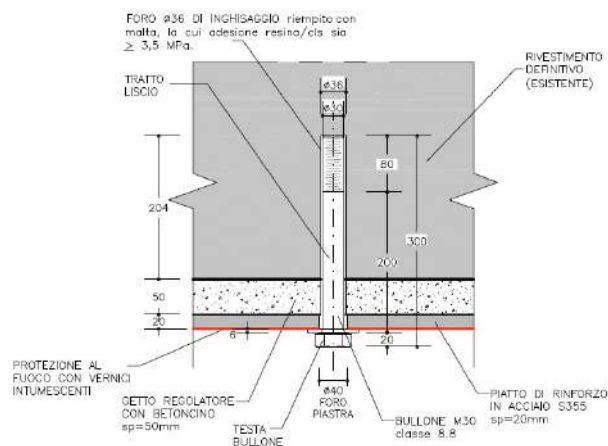

Figure 10. Intervention with steel plates: detail

## 7 CASE HISTORIES

Some of the interventions described in the chapter 6 have been applied for the restoration of tunnels part of the Bologna-Florence Motorway (Lunardi et al. 2008) and a tunnel near Florence junction. In Figure 11 some typical vertical cracks, by concrete shrinkage, are reported: a repairing according to 6.1 or 6.2, depending on the crack's opening, was applied, after checked by crackmeter that the phenomena was stabilised.



Figure 11. Monitored vertical cracks

Figure 12 shows the typical trend of a crack's opening (red and blue lines) influenced by temperature variation (yellow line): it can be notice an increasing of opening during the winter period, with low temperatures, and a reclosure of the cracks in summer with the increasing temperatures. It's importance to assess the a growing trend is not present.

For longitudinal cracks, especially if located in crown (Fig. 13a), it is preferable to provide a strengthened intervention; it's necessary to check if the crack affects the entire thickness of the lining or not, performing a coring in the lining (Fig. 13b).

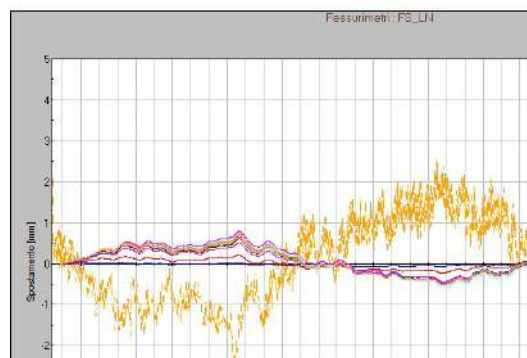

Figure 12. Variation of crack's opening vs temperature



Figure 13. a) Longitudinal crack, b) checked by coring

The following figures show a reinforcement with UHTSS galvanized steel fabric Steel Net 220, to repair part of a tunnel crown affected by cracks: the 300 mm tape is unrolled and positioned with specific mortars on the intrados of the tunnel's lining, in correspondence of the cracks, mechanically fixed with connectors (in this case steel stirrups have been used) and embedded in a layer of high performance mortar.



Figure 14. UHTSS steel net 200's application

The dimensioning of the reinforcement has to count the tensile strength of the steel fabric, equal to 6900 N/cm, and the delamination limit equal to  $f_{dd} = 1440 \text{ N/mm}^2$ . Considering the steel area, 272 mm<sup>2</sup>, the strength of the reinforcement system is easily evaluated (the use of a safety factor equal to 1.2 is suggested). Several

overlapping layers of Steel Net 220 can be used in order to determine the required resistance.

Steel Net 220 can be used for systematic reinforcement too, if the resistance of plain concrete linings is to be increased to support unexpected loads or seismic conditions. The steel fabrics are positioned along the entire profile of the tunnel intrados at a variable distance, normally in the range 1.20-1.80 m depending on the increase in resistance to be applied (see Figure 15).



Figure 15. Systematic lining reinforcement by Steel net and detailing of connector (SFIX G 12)

Finally, Figure 17 shows an example of using of steel plates to reinforce the sidewall of a tunnel where concentrated loads had been generated such as to create cracks in the lining (centimetric in width), concrete spalling and shear rupture. The problem was located at the intersection with a side adit, placed at an angle with respect to the axis of the main tunnel and built after it, which determined local stress concentrations.

A 3D Sap2000 model (Fig. 16) has allowed to evaluate in detail the state of stress present in the node and to dimension the necessary reinforcement. The model's results were compared and calibrated with the results of doorstopper tests, executed in the lining in the most significant points.

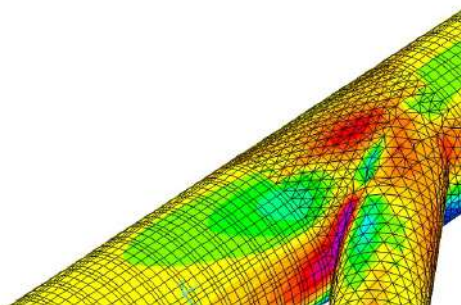

Figure 16. 3D FEM Model for local stresses' evaluation

20 mm steel S355 plates were used, connected to the lining by M30 bolts, 8.8 class, 280 mm in

length. The presence of the steel plates increase the USL M-N domain of the composite section (steel plus concrete) and introduce an additional shear strength mainly related to the steel plates.



Figure 17. Reinforcement of sidewall by steel plates

## 8 CONCLUDING REMARKS

Some options for the reinforcement of tunnels have been presented, defining the application's context and the technical requirements. It is important to focus that, in order to choose the proper intervention, it's necessary a detailed survey and investigation of the situation, able to evaluate the characteristics of the cracks and damages to be restored and the causes.

After the intervention has been carried out, it is necessary to prepare a monitoring program able of controlling the behaviour of the new structure and to subject it to a "maintenance program".

## REFERENCES

- Armelloni M., 2015. Il cemento? Ora è d'acciaio, *LeStrade*, 10/2015, 75-78.
- Bacchettini V., Corinaldesi V., Croce P., D'Antino T., Giacomello G., Giacomini G., Mele M., Moriconi G., Pasetto M., Pellegrino C., Vocca H., 2014. *Convegno nazionale AIPCR Roma 2014, CT 4.3 – Ponti stradali, AIPCR Associazione mondiale della strada.*
- Lunardi, P., Cassani, G. Gatti, M. 2008 *Design aspects of the new Apennines crossing on the A1 Milan-Naples motorway: the Base Tunnel, Proceeding of the AFTES Congrès International Monaco, Le souterrain: espace d'avenir.*
- Penzien, J., Wu, C.L., (1998). Stresses in linings of bored tunnels. *Earthq. Eng. Struct. Dyn.* 27 (3), 283–300.
- Penzien J (2000) Seismically induced racking of tunnel linings. *Earthq Eng Struct Dyn* 29:683–691.
- Perinelli, C., G. Giaconin, *Consolidamento delle opere d'arte sulla A14, Strade ed Autostrade giugno 2014*
- Wang, J.N., 1993. *Seismic design of tunnels: a simple state-of-the-art design approach.* Monograph, monograph 7. Parsons, Brinckerhoff, Quade and Douglas Inc, New York.